



UL-FM 350 PSI RESILIENT WEDGE GATE VALVE, FIGURE 5000'S, KS-RWHP, KS-FWHP 2½" – 12"

Overview

Kennedy Valve Figure 5000 KS-RWHP and KS-FWHP gate valves are resilient EPDM encapsulated ductile iron wedge gate valves that are used in fire protection systems and water service applications. They offer bubble tight, bi-directional, on-off flow control. Figure 5000s are compliant with AWWA C515 4" to 12" and UL Listed and FM Approved as KS-RWHP and AWWA C509 compliant 2½" to 3" and UL Listed and FM Approved as KS-FWHP and all are constructed of durable ductile iron formulated to ASTM 70-50-05.

The Figure 5000 family utilize triple EPDM o-ring stem seals and o-rings at the bonnet to body connection offering best in class performance and serviceability. The OS&Y utilizes a single o-ring and packing. The two uppermost stem o-rings of the NRS valve as well as OS&Y packing can be replaced while the valve is in service (consult our O&M for details).

Several end conditions are available including: flange by flange, both 125lb and 250lb class flanges, IPS groove by groove,

flanged by IPS grooved, mechanical joint, push on for both C900 PVC and ductile iron pipe, as well as flange by MJ.

All Figure 5000s are coated with a high-performance heat curable, thermosetting fusion bonded epoxy system. This Kennedy Valve Powder coating system is FDA Title 21 section 175.300 accepted and is AWWA C550 compliant.

All OS&Y valves are manufactured with pre-grooved stems to accommodate tamper switches by others.

All Kennedy KS-RWHPs and KS-FWHPs are manufactured and assembled at Kennedy Valve in Elmira, NY.

Manufacturing Standards - ISO 9001, ISO 14001, ISO 45001



The KVOS2 tamper switch is an available option on any Kennedy OS&Y, see page 5.



61/372



Technical Data

Available Sizes: 2½" to 12"

Maximum Working Pressure: 350psi

FLANGED

Stocked: ANSI B16.1 Flat Face Flange, CL 125, CL 150 Drilling

Optional: CL 250 Raised Face, CL 125 with PN16 Drilling

GROOVED

Grooved Ends Stocked: Standard IPS Grooves per ANSI/AWWA C606

FASTENERS

Stocked NRS: 304 Stainless Steel

OS&Y: Plated Steel

Optional: 316 Stainless Steel,

OS&Y also available in 304 Stainless Steel

STEM

NON-RISING GATE VALVE

Stocked: ASTM B584 High Strength Manganese Bronze

Optional: ASTM A276 Type 304ss, Type 316ss or ASTM B763 NDZ Bronze

OS&Y GATE VALVE

Stocked: ASTM A276 Type 304ss

Optional: ASTM A276 Type 316ss, ASTM B98 Silicon Bronze (Everdur), or ASTM B371 (Equal to: Eco Brass™)

BODY TAPPING

All 12" and down Kennedy KS-RWHPs & KS-FWHPs can be tapped at up to four locations: A, B, E, F. See figure 3 on page 3 for locations on the valve body. Grooved end valves are stocked with A, B, & F locations tapped. All taps are ¾" NPT except 4" and down flanged valves are ½" NPT taps. Plugs are low carbon steel, are coated over during the Kennedy Powder Coating process and can be either silicon bronze or low carbon steel. The plugs are easily removed by utilizing deep well 4-point sockets.

Components

NRS WITH POST PLATE

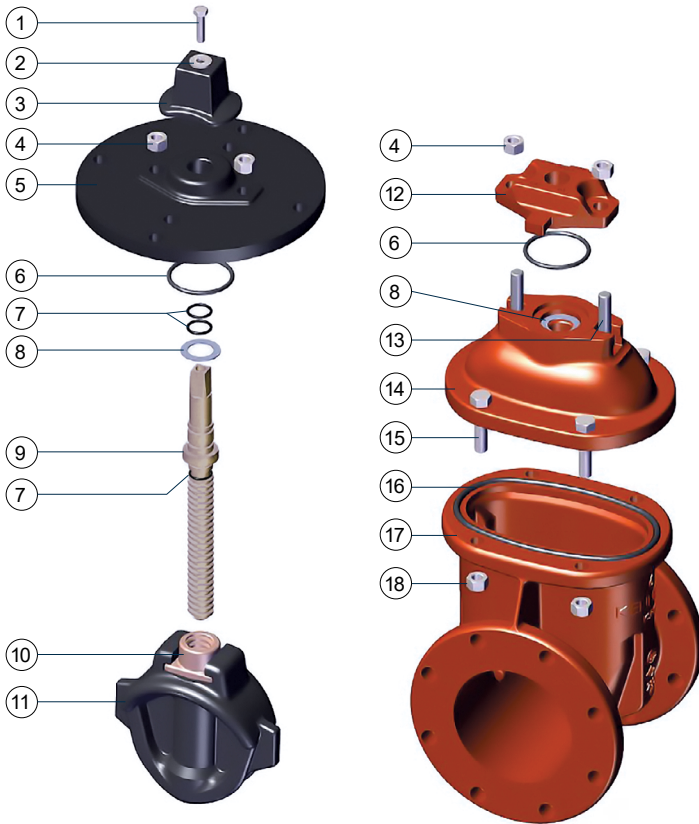

OS&Y

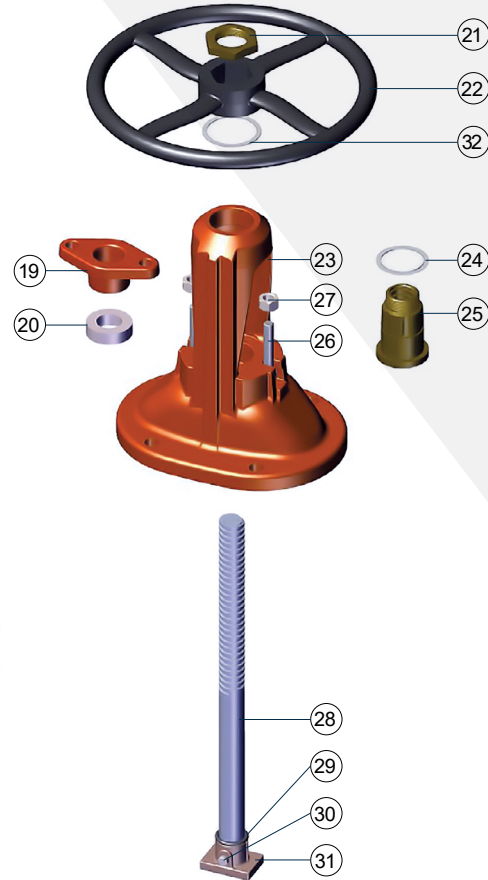

Figure 1

Dimensions

No.	NRS	OS&Y	Description	Material
1	•		Op-Nut Bolt	Stainless Steel
2	•		Op-Nut Washer	Stainless Steel
3	•		Op-Nut	Ductile Iron
4	•	•	Post Plate/Stuffing Box Nut	Stainless Steel
5	•		Post Plate	Cast Iron
6	•		Post Plate/Stuffing Box O-Ring	Rubber
7	•	•	Stem O-Rings	Rubber
8	•		Thrust Teflon Washer	Plastic
9	•		Stem	Manganese Bronze
10	•		Stem Nut	Bronze
11	•	•	Resilient Wedge	EPDM Encapsulated Ductile Iron
12	•		Stuffing Box	Ductile Iron
13	•		Post Plate/Stuffing Box Plate Bolt	Ductile Iron/Stainless
14	•	•	Cover	Ductile Iron
15	•	•	Bonnet/Cover/Body Bolt	Plated Steel (OS&Y) Stainless Steel (NRS)
16	•	•	Bonnet/Cover/Body O-Ring	Rubber

No.	NRS	OS&Y	Description	Material
17	•	•	Body	Ductile Iron
18	•	•	Bonnet/Cover/Body Nut	Plated Steel (OS&Y) Stainless Steel (NRS)
19		•	Packing Gland	Ductile Iron
20		•	Packing	Garlock Style 18
21		•	Handwheel Nut	Bronze
22		•	Handwheel	Cast Iron
23		•	Bonnet/Cover	Ductile Iron
24		•	Yoke Washer	Plastic
25		•	Yoke Nut	Bronze
26		•	Packing Bolt	Plated Steel
27		•	Hex Nut	Brass
28		•	Stem	Pre-Grooved Stainless Steel
29		•	Stem O-Ring	Rubber
30		•	Stem Pin	Stainless Steel
31		•	Stem Nut	Bronze
32		•	Handwheel Yoke Washer	Brass

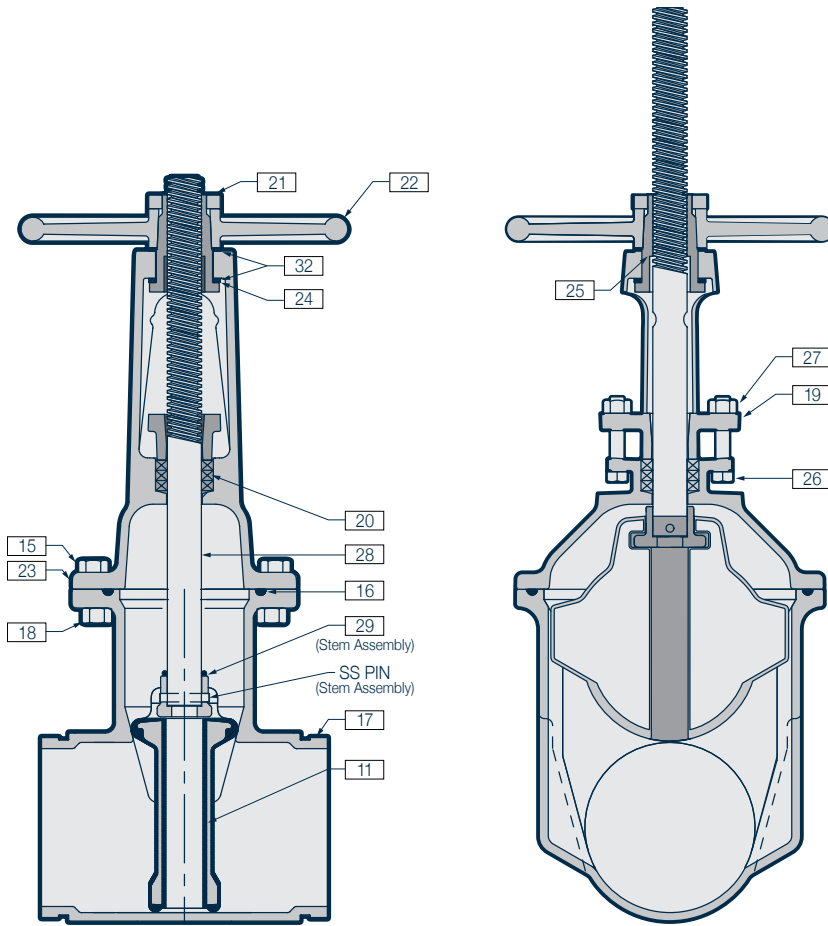

Figure 2

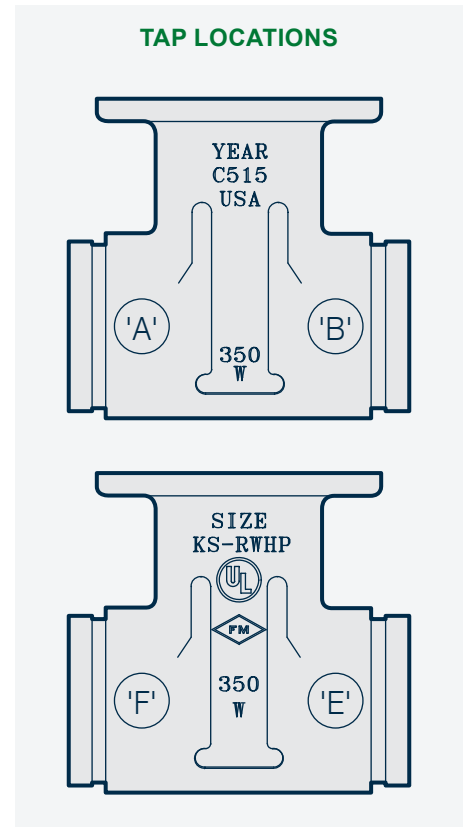

Figure 3

Bill of Materials

Item	Description	No Req'd	Material
21	Handwheel Nut	1	Bronze ASTM B584 C89833, 87850
22	Handwheel	1	Cast Iron ASTM A-126 Class B
32	Thrust Washer (upper/lower)	1 ea	Bronze ASTM B36 (2"/2.5" Delrin/Celcon)
24	Anti-Friction Bearing	1	Nylatron Sizes 3" - 12"
15/18	Hex Head Bolts / Hex Nuts	varies	Plated Steel
23	Bonnet/Cover	1	Ductile Iron ASTM A-536 (65-45-12) or Ductile Iron ASTM A-536 (70-50-5)
20	Packing	1	Square Braided Non-Asbestos
28	Stem	1	304 Stainless Steel
16	O-Ring	1	Buna-N
29	O-Ring (Stem Assembly)	1	Buna-N
17	Body	1	Ductile Iron ASTM A-536 (65-45-12) or Ductile Iron ASTM A-536 (70-50-5)
11	Resilient Wedge	1	DI ASTM A-536 (65-45-12 or 70-50-5), EPDM Encapsulated Wedge
25	Yoke Nut	1	Bronze ASTM B584 C86700
27	Hex Nuts	2	Brass
19	Gland	1	Ductile Iron ASTM A-536 (65-45-12) or Ductile Iron ASTM A-536 (70-50-5)
26	Square Head Bolts	2	Plated Steel

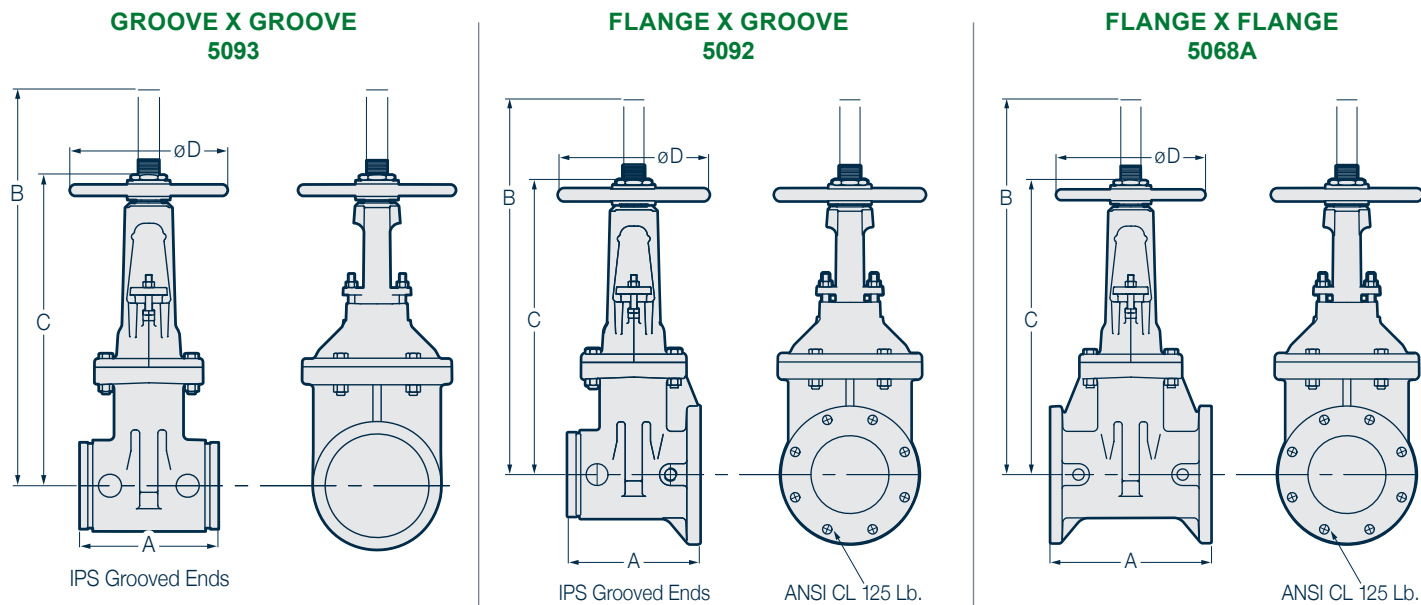

Figure 4

DIMENSIONS, WEIGHT, AND OPERATIONAL DATA - FIG. 5093, FIG. 5092, FIG. 5068A

Size	Nominal Dimensions				No. of Bolts and Bolt Size per Flange	Turns to Operate	Weights in Pounds			Cv Full Open
	A	B	C	ØD			G x G	G x F	F x F	
2½"	7½"	16⅜"	13⅞"	10"	4 (⅝")	8	37	40	52	500
3"	8"	18⅞"	15⅝"	10"	4 (⅝")	10	48	57	67	800
4"	9"	22¾"	18¼"	10"	8 (⅝")	13½	74	77	92	1500
6"	10½"	30⅞"	23¾"	12"	8 (¾")	19½	103	115	141	3600
8"	11½"	37¾"	29¼"	14"	8 (¾")	25½	139	171	213	6700
10"	13"	45¾"	35⅝"	18"	12 (⅞")	31½	294	N/A	369	10,500
12"	14"	53⅞"	40⅝"	18"	12 (⅞")	37¾	326	N/A	479	15,000

DIMENSIONS, WEIGHT, AND OPERATIONAL DATA - ANSI CL 250 RF FLANGED OS&Y - FIG. 5168

Size	Nominal Dimensions				No. of Bolts (size per flange)	Turns to Operate	Weights in Pounds		Cv Full Open
	A	B	C	ØD			F x F		
2½"	8⅝"	18⅞"	15⅝"	10"	8 (¾")	10	81	500	
3"	8⅝"	18⅞"	15⅝"	10"	8 (¾")	10	81	800	
4"	11¾"	22¾"	18¼"	10"	8 (¾")	13	116	1500	
6"	13⅝"	30⅞"	23¾"	12"	12 (¾")	19	165	3600	
8"	14⅞"	37¾"	29¼"	14"	12 (⅞")	25	275	6700	
10"	14 ¹⁹ / ₆₄ "	45¾"	35⅝"	18"	16 (1")	31½	447	10,500	
12"	15⅝"	53⅞"	40⅝"	18"	16 (1⅝")	37¾	580	15,000	



Resilient Seated Gate Valves w/KVOS (Factory Installed Tamper)

KSRW OS&Y – FLANGED, FLANGED X GROOVE, GROOVE & ENDS GENERAL INFORMATION

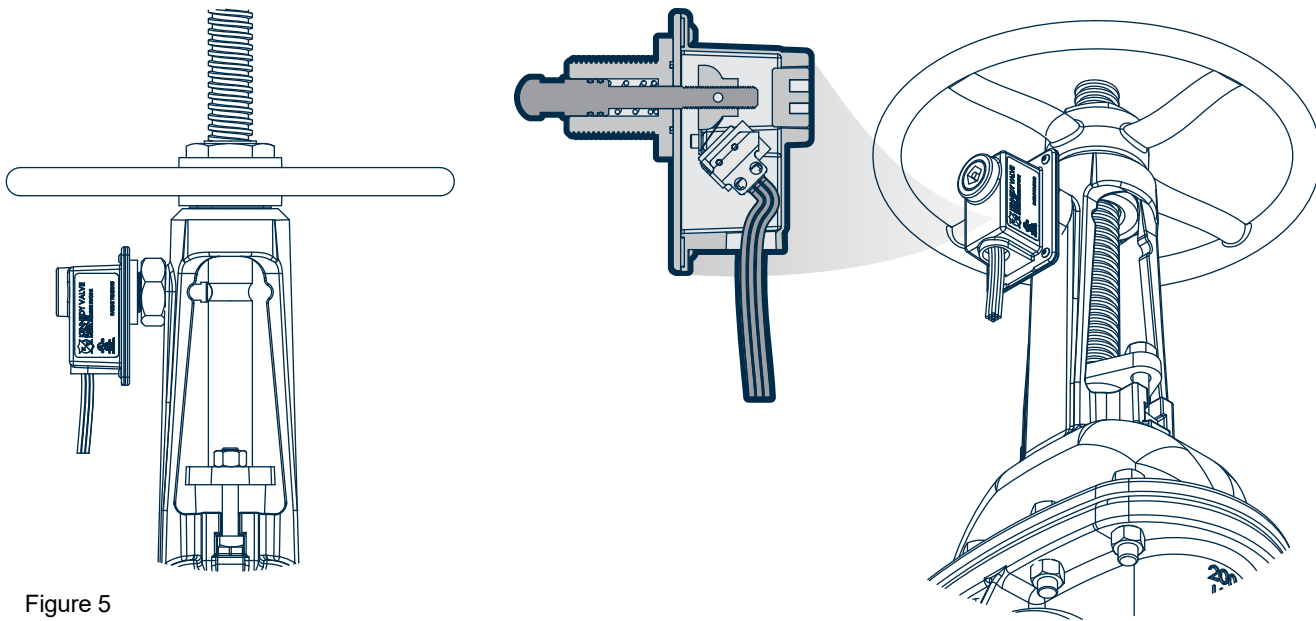

Figure 5



KVOS-2 FOR KSRW/KSRWHP 3"-12"

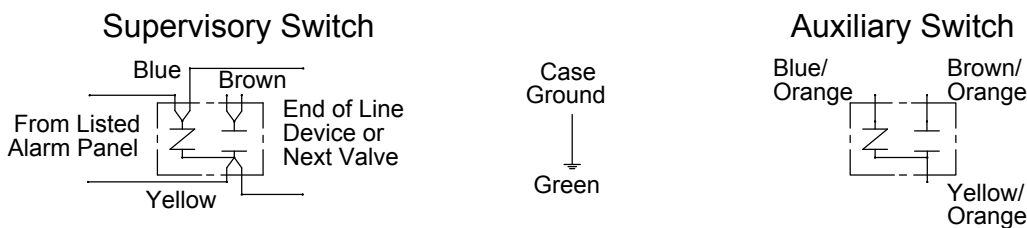

Figure 6

Rated: 120 VAC, 28 VDC, .25 A

WIRING NOTES: Connection to power limited circuitry is required. Auxiliary switch is for supplemental use only, and shall not be used for fire alarm signaling applications.

Switches are checked at factory, check continuity with valve fully open, switches activate within two turns from open.

CAUTION: PRIOR TO INSTALLATION OF SUPERVISORY SWITCHES IN FIRE PROTECTION SYSTEMS REFER TO THE FOLLOWING STANDARDS:

NFPA 13: STANDARD FOR THE INSTALLATION OF SPRINKLER SYSTEMS

NFPA 25: INSPECTION, TESTING, MAINTENANCE OF WATER BASED FIRE PROTECTION SYSTEMS

NFPA 70: NATIONAL ELECTRICAL CODE

NFPA 72: NATIONAL FIRE ALARM CODE

CSA C22.1 NO.1 CANADIAN ELECTRICAL CODE, PART 1, SAFETY STANDARD FOR ELECTRICAL INSTALLATIONS SECTION 32

CAN/ULC-S524, STANDARD FOR INSTALLATION OF FIRE ALARM SYSTEMS

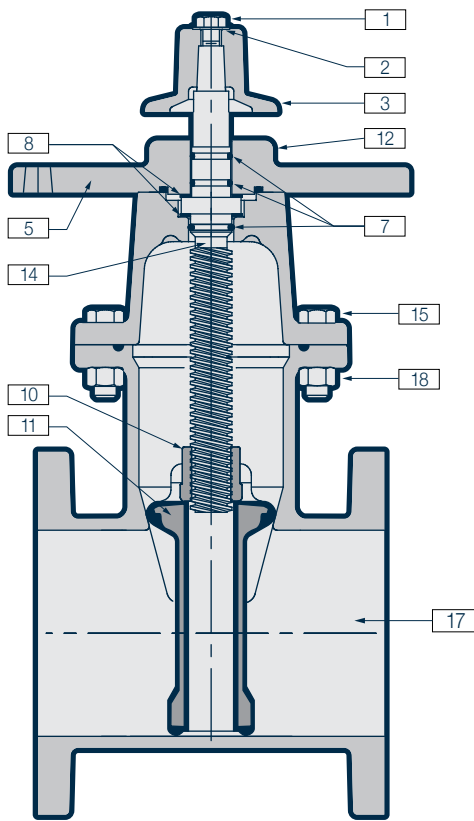

Figure 7

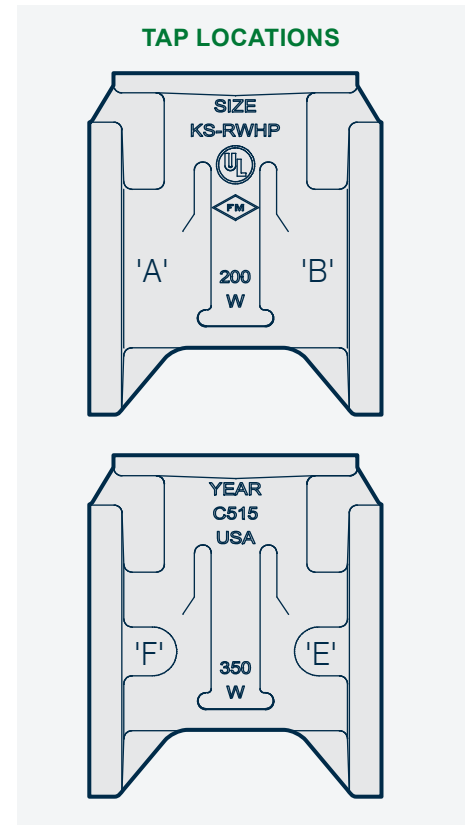
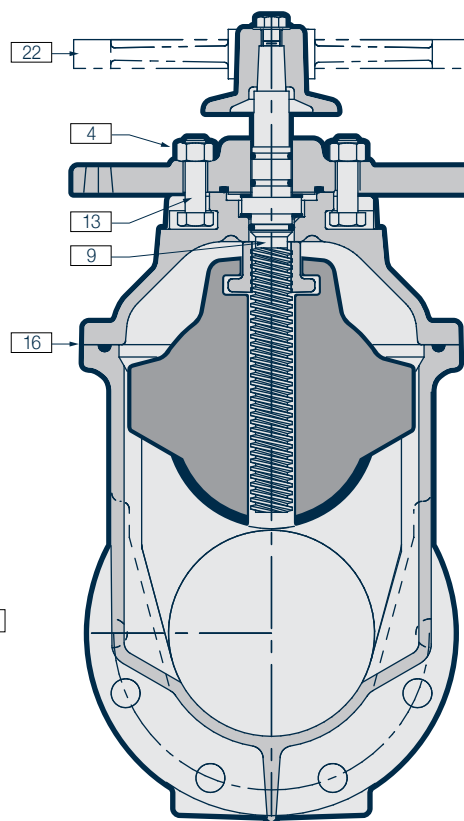

Figure 8

Bill of Materials

Item	Description	No Req'd	Material
1	Hex Head Bolt	1	18-8 Stainless Steel, ASTM F593C
2	Flat Washer	1	Steel, Plated
3	Operating Nut	1	Cast Iron ASTM A-126 Class B
12	Stuffing Box	1	Ductile Iron ASTM A-536
8	Thrust Washer	1	2" & 2.5" Delrin
		2	3" - 12" Delrin
5	Post Adaptor Plate (Optional)	1	Cast Iron ASTM A126 Class B (4 - ¼" holes on a 10½" diameter B.C.)
14	Cover	1	Ductile Iron ASTM A-536 (70-50-5)
10	Stem Nut	1	Bronze ASTM B-763 C99500
11	EPDM Encapsulated Wedge	1	Ductile Iron ASTM A-536 (70-50-5)
12	Stuffing Box	1	Ductile Iron ASTM A-536
7	O-ring (Stem)	3	Buna-N
15	Hex. Head Bolts		18-8 Stainless Steel, ASTM F593C
18	Hex. Nuts		18-8 Stainless Steel, ASTM F594
17	Body	1	Ductile Iron ASTM A-536 (70-50-5)
22	Handwheel (Optional)	1	Cast Iron ASTM A-126 Class B
4	Hex. Nuts	2	18-8 Stainless Steel, ASTM F593C
13	Stuffing Box Bolts	2	18-8 Stainless Steel, ASTM F593C
9	Stem	1	Bronze ASTM B584 C86700 (STD) OR Bronze NDZ ASTM B763 C99500 OR 304 Stainless Steel ASTM A479
16	O-ring (Cover)	1	Buna-N

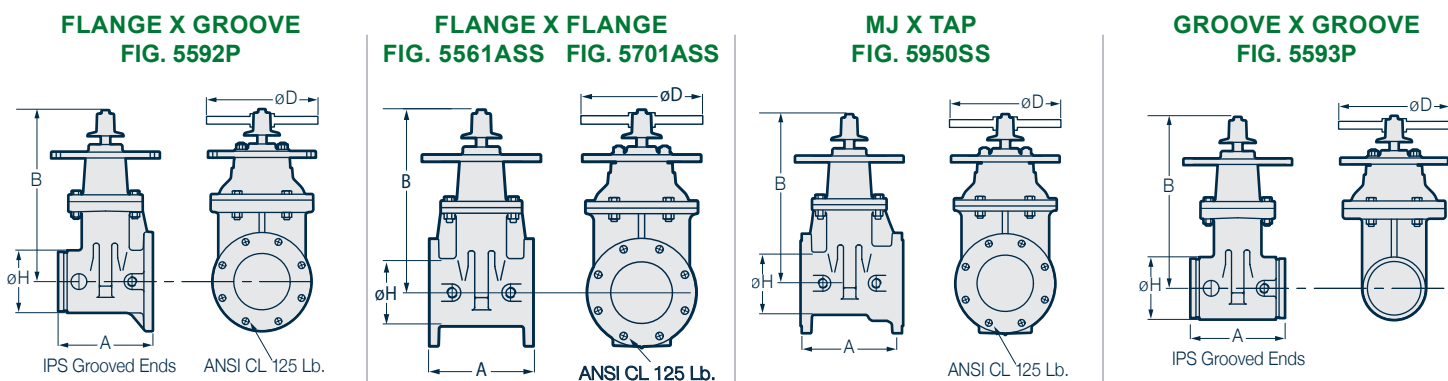

Figure 9

**DIMENSIONS, WEIGHT, AND OPERATIONAL DATA -FIG. 5592P/ 5561ASS/ 5701ASS/ 5950SS/ 5593P NRS
FLANGED END ANSI CL 125, GROOVED, GROOVED BY FLANGED, FLANGE X MJ TAPPING (4" TO 12" ONLY)**

Size	Nominal Dimensions			No. of Bolts per Flange and Bolt Size	Weight 5701ASS (with plate)	Weight 5561ASS	ØD Optional Handwheel Diameter	Turns to Operate	Cv Full Open
	A	ØH	B						
2½"	7½"	2½"	11¾"	4 (5/8")	65	52	7¼"	8	500
3"	8"	3"	12¾"	4 (5/8")	79	68	10"	10	800
4"	9"	4¼"	14¾"	8 (5/8")	102	78	10"	13½	1500
6"	10½"	6¼"	19"	8 (¾")	139	119	12"	19½	3600
8"	11½"	8¼"	22½"	8 (¾")	208	201	14"	25½	6700
10"	13"	10¼"	26½"	12 (7/8")	340	325	18"	31½	10500
12"	14"	12¼"	30"	12 (7/8")	446	430	18"	37¾	15000

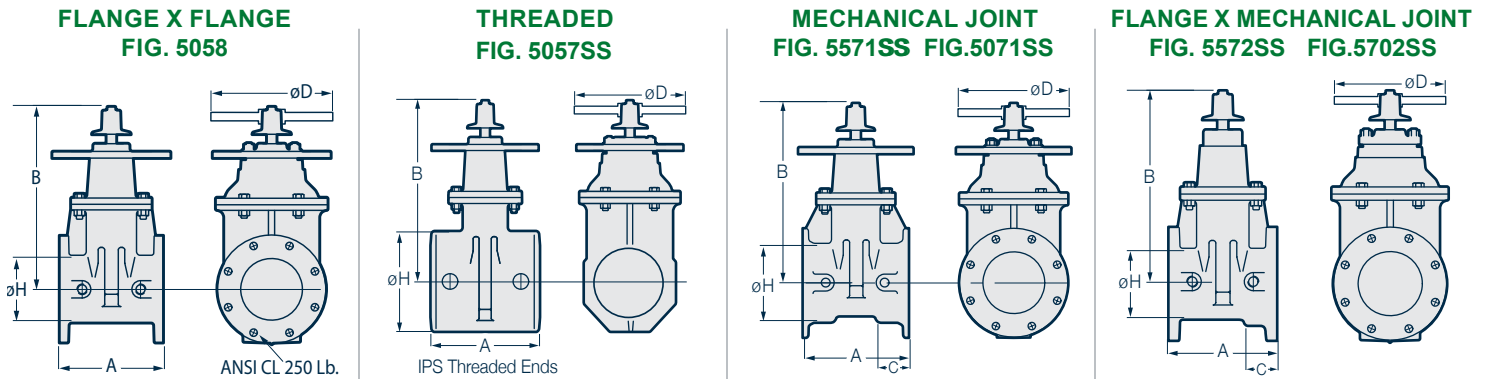

Figure 10

Size	Nominal Dimensions			C	No. of Bolts	Weight	Weight	ØD	Turns to	Cv Full
	A	ØH	B	(depth of socket)	per Flange and Bolt Size	with Plate	w/o Plate	Optional Handwheel Diameter	Operate	Open

DIMENSIONS, WEIGHT, AND OPERATIONAL DATA - CLASS 250 FLANGE - FIG. 5058 / FIG. 5058PSS

2½"	8.63"	3⅞"	12⅝"		8 (¾")	95	81	10"	8	500
3"	8.63"	3⅞"	12⅝"		8 (¾")	95	81	10"	10	800
4"	11¾"	4¼"	14¾"		8 (¾")	117	102	10"	13½	1500
6"	13⅝"	6¼"	19"		12 (¾")	182	167	12"	19½	3600
8"	14⅞"	8¼"	22½"		12 (⅞")	268	253	14"	25½	6700
10"	14⅞"	10¼"	35½"		16 (1")	355	340	18"	31½	10500
12"	14⅞"	12¼"	40⅓"		16 (1⅝")	495	480	18"	37¾	15000

DIMENSIONS, WEIGHT, AND OPERATIONAL DATA - THREADED - FIG. 7057

2½"	7		11⅝"		N/A	N/A	34	6"	8	500
3"	7¼"		12⅝"		N/A	N/A	47	10"	10	800

DIMENSIONS, WEIGHT, AND OPERATIONAL DATA - MJ - FIG. 5571 / FIG. 5071

3"	8½"	3"	12⅝"	2½"	4 (⅝")	N/A	59	10"	10	800
4"	9½"	4¼"	14¾"	2½"	4 (¾")	91	70	10"	13½	1500
6"	10½"	6¼"	19"	2½"	6 (¾")	128	110	12"	19½	3600
8"	13⅝"	8¼"	22½"	2½"	6 (¾")	189	164	14"	25½	6700
10"	15½"	10¼"	26½"	2½"	8 (¾")	302	287	18"	31½	10500
12"	16"	12¼"	30"	2⅝"	8 (¾")	385	362	18"	37¾	15000

DIMENSIONS, WEIGHT, AND OPERATIONAL DATA - FLG X MJ - FIG. 5572 / FIG. 5702

3"	8¼"	4⅓/100"	12⅝"	2½"	4 (⅝") 4 (⅝")	N/A	59	10"	10	800
4"	9¼"	4¼"	14¾"	2½"	8 (⅝") 4 (¾")	91	70	10"	13½	1500
6"	10½"	6¼"	19"	2½"	8 (¾") 6 (¾")	128	110	12"	19½	3600
8"	12⅝/16"	8¼"	22½"	2½"	8 (¾") 6 (¾")	189	164	14"	25½	6700
10"	14¼"	10¼"	26½"	2½"	12 (⅞") 8 (¾")	302	287	18"	32	10500
12"	15"	12¼"	30"	2⅝"	12 (⅞") 8 (¾")	385	362	18"	37¾	15000

*AWWA C509 compliant