



KENNEDY VALVE

**2"-12" R/S OS&Y FLANGED GATE VALVES
GENERAL DIMENSIONS**

MODEL 5068A W/ HANDWHEEL 350 PSI RATING

NOTE:
CONFORMS TO DIMENSIONAL, MATERIAL & TEST REQUIREMENTS 350 PSI RATING
AWWA C515 - MODEL 'KS-RW'
AWWA C509 - MODEL 'KS-FW' IN DUCTILE
ASME B16.1 CLASS 125 FLANGES

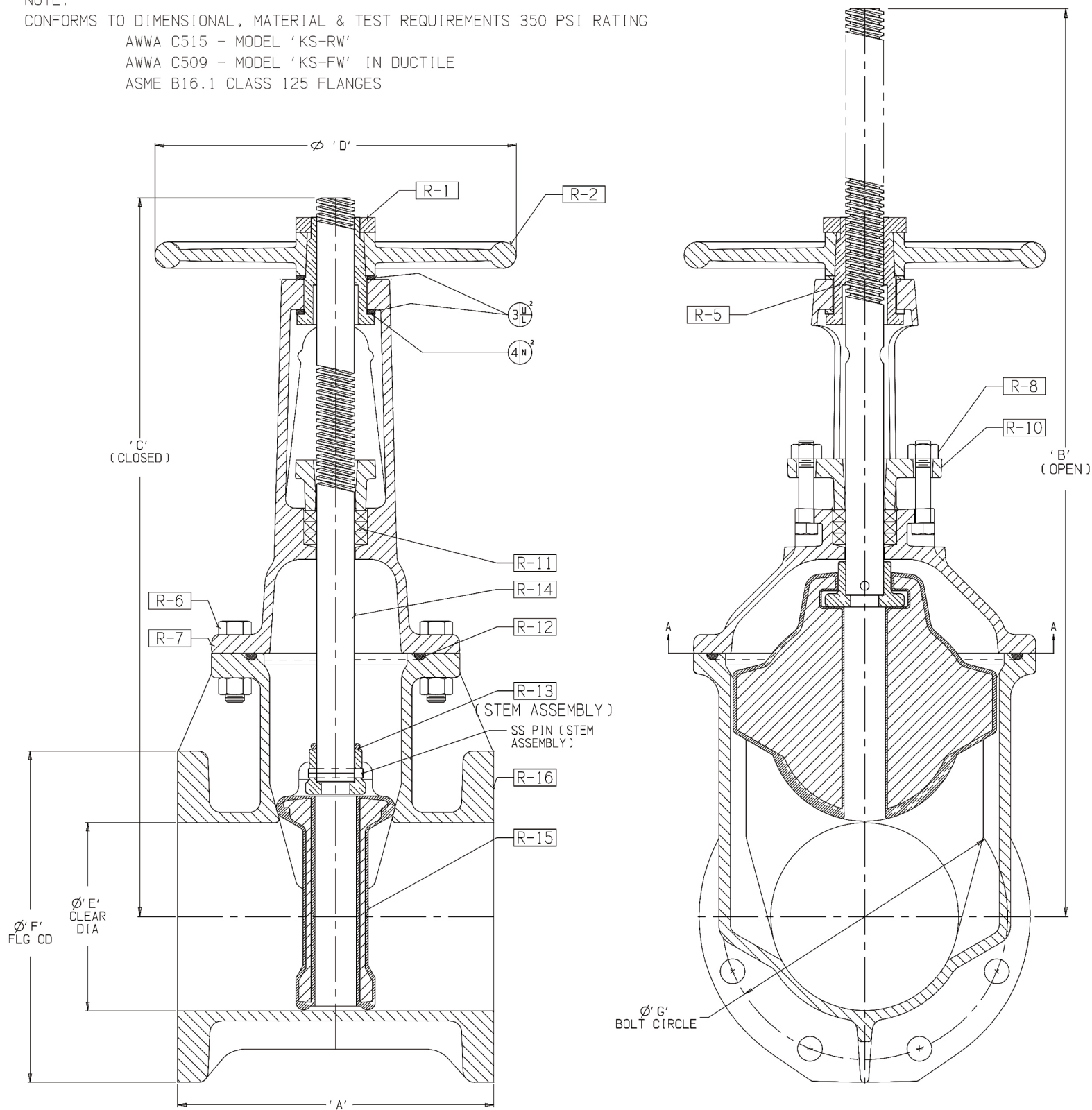

ALL FLANGE VALVES TAPPED & PLUGGED @ POSITION "A"

SIZE	Model(s)	A	B	C	D	E	F	G	No. TURNS to OPEN
2"	KS-FW	7"	15 7/16	13 3/32	7 1/4"	2.00	7.00	4.75	6.5
2 1/2"	KS-FW	7 1/2"	16 3/8"	13 7/8"	7 1/4"	2.50	7.50	5.50	8
3"	KS-FW	8"	18 7/8"	15 5/8"	10"	3.00	8.00	6.00	10
4"	KS-RW & KS-FW	9"	22 3/4"	18 1/4"	10"	4.25	9.00	7.50	13 1/2
6"	KS-RW & KS-FW	10 1/2"	30 1/8"	23 3/4"	12"	6.25	10.50	9.50	19 1/2
8"	KS-RW & KS-FW	11 1/2"	37 3/4"	29 1/4"	14"	8.25	11.50	11.75	25 1/2
10"	KS-RW & KS-FW	13"	45 3/4"	35 3/8"	18"	10.25	13.00	14.25	31 1/2
12"	KS-RW & KS-FW	14"	53 1/8"	40 5/8"	18"	12.25	14.00	17.00	37 3/4